

Induced Energy Limited operates a continuous programme of product development and improvement. Product specifications may therefore be subject to change.

iPlate

Installation Instructions

Drop-in Induction Hot Plate

Visible Version: Ceran or Swanstone

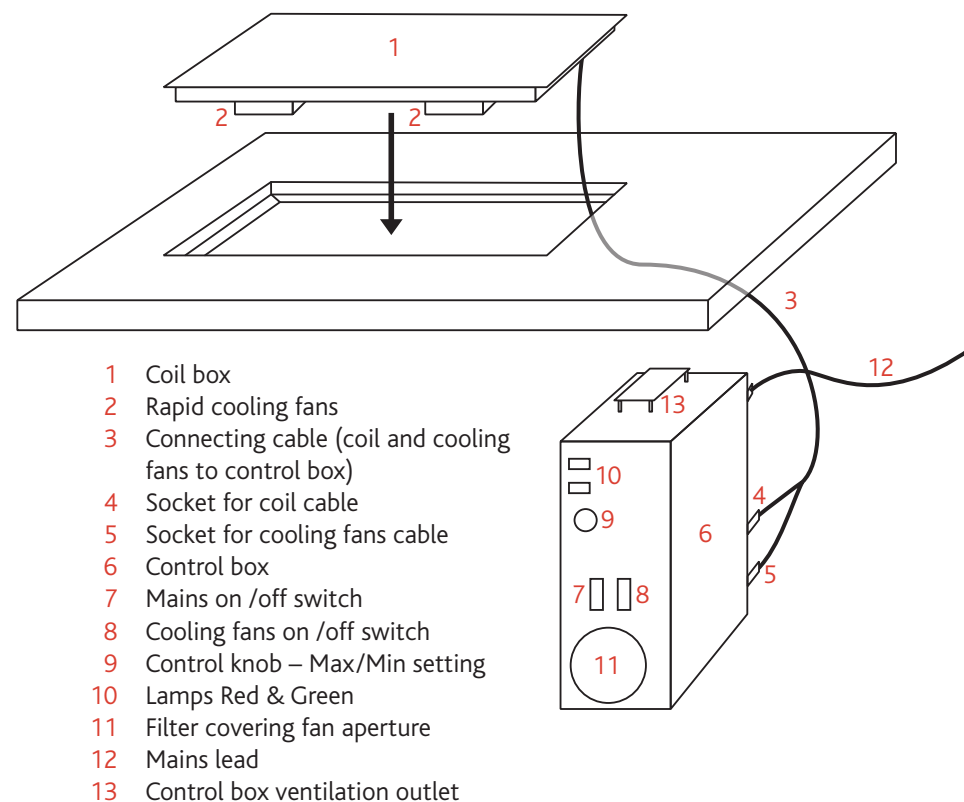

Induced Energy Limited
Westminster Road
Brackley
Northants
NN13 7EB
Tel: 01280 705900
Fax: 01280 705270
email: sales@inducedenergy.com



Induced Energy

Professional Induction Hobs

www.inducedenergy.com

For a successful installation, please follow these simple instructions

Only qualified personnel should be employed to carry out the installation of the iPlate.

iPlate Pre-Installation Checklist

1. Parts Check List

Carefully unpack unit and check the following parts are complete:-

Item	Quantity
Drop-in coil box	1
Ceran glass or Swanstone top	1
Control box	1
Tube of mastic	1
Masking tape	1

2. Safety Check

If the iPlate casing, glass, Swanstone top or control box are damaged, do not proceed. Contact your supplier.

3. Check Electricity Supply

Ensure that there is a 13 amp electrical socket available within the housing unit and that it is operational. It is essential that the correct polarity is observed and that the live pin is connected to the Brown positive supply and the Blue to the negative supply. Earth is green/yellow. Hard wiring the unit into the electrical supply may invalidate the warranty.

Cutting the aperture for the coil box.

Cut a rebated aperture in the counter where the iPlate is to be positioned.

The actual aperture must be 710 wide x 595mm deep

The rebate must provide a 15mm lip on which the coil box will rest.

The rebate should be 9mm deep from the top of the counter surface.

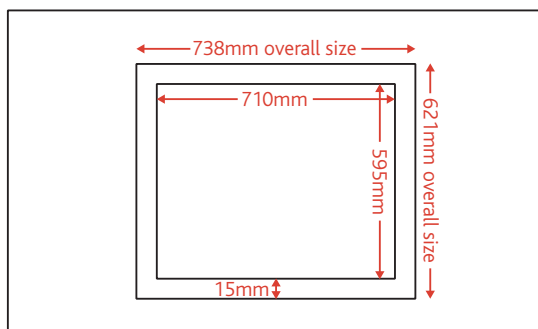

iPlate Installation

1. BEFORE PROCEEDING, ENSURE THAT THE ELECTRICAL POWER SUPPLY TO THE UNIT IS SWITCHED OFF.

- Lift up the coil box and hold it over the rebated aperture. Feed the connecting cable through the aperture, then lower the coil box into the aperture. Ensure the coil box is supported by the rebate and is centrally positioned.
- Connect the coil box to the control box via the 2 plugs. The coil cable is connected via a special twist and lock plug which is inserted and then twisted clockwise until the safety catch clicks into place. The fan cable is pushed into place as usual. Plug the control box into a suitable 13 amp mains electrical supply and switch on. Switch on the control box at the rocker switch and test the unit as follows:-

Initially there will be a brief lamp test when both red & green lights alternate on & off. Turn the mains rocker switch on. (The green light flashes on and off while the unit is operational). Ensure the control knob is set at the highest setting (fully clockwise) Place an induction-friendly container on the iPlate and check that it starts to heat up. After a successful test switch the control box off at the rocker switch and the mains supply. Disconnect the connecting cables.

If the unit fails to heat the induction-friendly container (containers can be checked for their suitability by testing with a magnet. A magnet must stick to the base of the container) check all power connections and mains supply. If the unit still fails to heat the container call your supplier or +44 (0) 1280 705900 for further advice.

- To seal the Ceran or Swanstone first mask off the edges of the Ceran glass or Swanstone and the aperture. Apply a bead of black mastic evenly between counter aperture and Ceran glass/ Swanstone using a suitable tool to produce a water-tight seal. There is no need to seal the coil box to the counter top. Remove & discard masking tape. Leave for 4 hours for the mastic sealer to cure before use.
- Mount the control box vertically within the unit housing with the fan filter at the base. Ensure there is no obstruction to the filter & the fan which is behind it, nor to the ventilation outlet on top of the control box. The control box fan will come on automatically if the temperature of the control box reaches 50C and goes off when the temperature drops to 46C.
- If you experience any problems please call us on +44 (0) 1280 705900 for further assistance.